

# Quadro®

SOLIDS SOLUTIONS FOR THE FOOD INDUSTRY

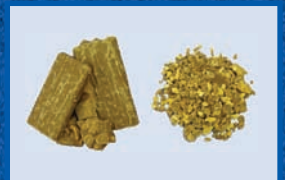



# QUADRO® SOLIDS SOLUTIONS IN THE FOOD INDUSTRY

## Delivering Higher Efficiencies and Cost Savings for You

### QUADRO® COMIL®

#### HIGH CAPACITIES

- 50% more throughput than conventional mills due to Comil®'s bulk feeding capability

#### LOW HEAT

- excellent for milling products with low melting points

#### LOW DUST

- significant cost savings by eliminating or reducing dust collection/explosion protection devices
- minimal product loss for 95% yields
- reduced disposal fees due to minimal product loss

#### LOW ENERGY USAGE

- up to 60% reduction in energy consumption for similar capacities with conventional mills

#### EASY-CLEAN

- minimal surface area and easy product flow design ensures unit can be cleaned in minutes

#### EASY-TO-USE

- easy-to-use controls minimize operator training requirements and increase operation accuracy
- can be control or bulk-fed eliminating costly, hard-to-clean feeders

#### VERSATILE

- wide range of screens and impellers available to meet any process requirement
- one unit is able to process a wide range of products with minimal investment

#### SPECIFICATIONS

MODEL		G97	G96	G98	In-line G20
Capacities	lbs/hr	800	35,000	60,000	15,000
	kg/hr	360	15,900	27,000	6800
Minimum Inlet to Outlet Height	in	13	8.6-36	17.7	14.5
	mm	330	219-914	450	368
Screen Diameter	in	5	12	24	8
	mm	127	305	605	203
Power	HP	1	10	20	5
	kW	0.75	7.5	15	4
RPM		1200-4800	450-1800	225-900	700-2800

(1) Capacities may be higher/lower than listed based on product characteristics, particle granulometry, inlet and discharge conditions. Consult your local Representative or Quadro for product testing.

(2) For some products/screen selections, capacities will exceed 99,000 lbs/hr (45,000 kg/hr).



#### SOME SAMPLE APPLICATIONS

Heat-sensitive, sticky and difficult materials can be size reduced continuously at a high capacity without excessive heat build-up or screen blockage. The Comil® can:

- produce free-flowing particles, chunky paste, fine paste or syrup
- disperse fat homogeneously in baking and flavor mixes to reduce finishing time (doughnuts, pancakes, muffins, cakes, flavor ingredients and soup mixes)
- size reduce for reclaim of snack foods (candies, cream-filled wafers, chocolate bars, cookies, granola bars, chewing gum)
- deagglomerate/delump sticky, hot cooked cereal to uniform pieces prior to flaker and dryer, and powders such as sugar, starch, flour, gelatin and cocoa
- deagglomerate spray-dried products such as cheese or milk products, dairy and non-dairy creamers
- fine-tune bulk density of various powders

#### CUSTOMIZABLE TO FIT A

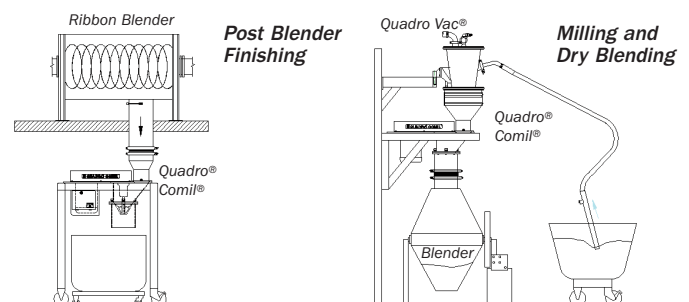

TRY

# Today's Food Processor



**Quadro® FlexSift Model GS20**  
(with standard finish)

## SOME SAMPLE APPLICATIONS

Agglomerated and difficult-to-process materials can be screened at a high capacity without excessive heat build-up. The Quadro® FlexSift can:

- security screen and delump food ingredients such as spices, seasonings, dairy powders and flavors
- bulk screen and delump flour, sugar and salt
- screen and delump nutraceutical powders prior to tableting or encapsulation

## ANY PROCESS STREAM

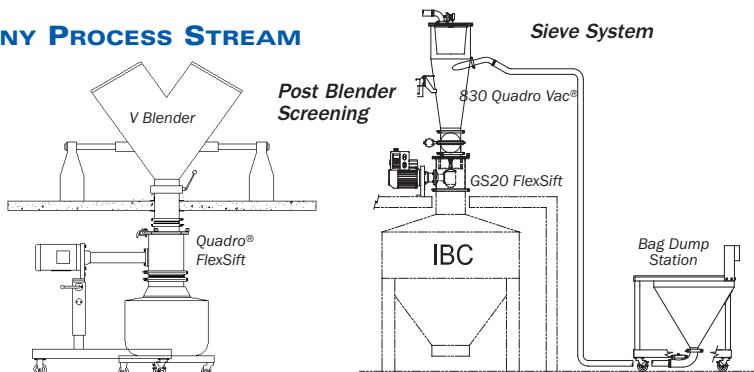

## QUADRO® FLEXSIFT

### COMPACT, IN-LINE DESIGN

- low profile design fits below most bulk bag unloader and mixer discharges
- dust-tight design prevents loss of product and need for expensive personal protective equipment
- reduces floor allocation requirements by 50%, as compared to conventional deck sifters

### POSITIVE, 360° DISCHARGE

- effectively segregates/retains impurities and other foreign materials, cutting sifting times up to 80%

### USER-FRIENDLY DESIGN

- easy-to-use controls minimize operator training requirements and increase operation accuracy
- can be control or bulk-fed eliminating costly, hard-to-clean feeders

### EASY-TO-CLEAN/MAINTAIN

- minimal number of parts - single bolt locking mechanism secures the screen assembly onto the gearbox for fast changeover and maintenance in minutes, not hours
- quick screen changes with no special tools required
- sanitary design reduces cleaning times by 50%, as compared to traditional sifters

### WIDE VARIETY OF OPTIONS AVAILABLE

- delump agglomerated material with the addition of the spoiler assembly - eliminates need for a lumpbreaker
- hand-feed hopper
- wide range of perforated (not woven) screen sizes available to meet your specifications

## SPECIFICATIONS

MODEL		GS20 FlexSift
Capacities	lbs/hr	38,500
	kg/hr	17,500
Minimum Inlet to Outlet Height	in	14.5
	mm	368
Screen Diameter	in	8
	mm	203
Power	HP	5
	kW	4
RPM		700-1400

(1) Capacities may be higher/lower than listed based on product characteristics, particle granulometry, inlet and discharge conditions. Consult your local Representative or Quadro for product testing.

(2) For some products/screen selections, capacities will exceed 99,000 lbs/hr (45,000 kg/hr).

# QUADRO PROCESS PRODUCTIVITY SOLUTIONS

For over 30 years, Quadro has made an unparalleled commitment to delivering the highest production efficiencies, product quality and consistency to market leaders in the Pharmaceutical, Food, Fine Chemical, Personal Care and Cosmetics industries worldwide.

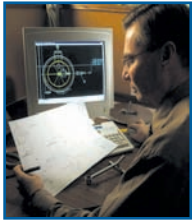

With the engineering experience gained from developing reliable application-specific solutions for major processors in more than 80 countries, our knowledge of size reduction and dispersion is unmatched.

In fact, meeting the evolving needs of our customers drives the development of some of the industry's most advanced processing technologies and systems – such as the *Quadro® Comil®*, *Quadro® FlexSift*, *Quadro® Fine Grind*, *Quadro Ytron®* in-line mixers, dispersers and emulsifiers, *Quadro® ShearFX*, *Quadro® HV-Emulsifier* and *Quadro Vac®* vacuum transfer systems.

Since 1976, Quadro has led the industry in research & development. Through the Quadro R&D Test Center we work

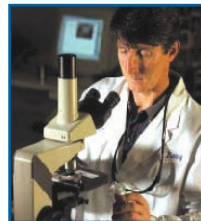

directly with our customers to run real-world tests of their processes on the latest Quadro equipment. The result has been technical breakthroughs that have changed the way many of our customers manufacture, and led to new global processing industry standards.

As the world's leading supplier of size reduction technology – with a vast global network of agents, distributors, OEMs and partners – Quadro provides a level of service and technical support that is unequaled in the industry. Our passion for technology is exceeded only by our dedication to meeting the needs of our customers.



**SIZE REDUCTION • FLUID MIXING • PNEUMATIC TRANSFER**



**LOCAL REPRESENTATIVE**



613 Colby Drive  
Waterloo, ON, CA N2V 1A1



630 Dundee Road, Suite 400  
Northbrook, IL 60062-2745

**Canada & International** T 519-884-9660  
**USA** T 973-376-1266  
**All Locations** F 519-884-0253

sales@quadro.com • www.quadro.com